



IKUMA 2

Technical specifications



TECHNICAL DATA

			22	24	26	28	30
CELLS	Number		61	61	61	61	61
ASPECT RATIO	Flat		5,7	5,7	5,7	5,7	5,7
AREA	Flat	m2	22	24	26	28	30
	Projected	m2	18,84	20,55	22,27	23,98	25,69
SPAN	Flat	m	11,2	11,7	12,17	12,63	13,07
CHORD	Maximum	m	2,41	2,51	2,62	2,71	2,81
LINES	Total	m	232	243	253	263	272
	Main		2-1/4/3	2-1/4/3	2-1/4/3	2-1/4/3	2-1/4/3
RISERS	Number	3+1	A-A'/B/C	A-A'/B/C	A-A'/B/C	A-A'/B/C	A-A'/B/C
	Accelerator	mm	145	145	145	145	145
WEIGHT IN FLIGHT	Min-Max	Kg	65-85	75-95	85-105	95-115	105-130
GLIDER WEIGHT		Kg	4,1	4,4	4,6	4,9	5,2
CERTIFICATION	EN/LTF		B	B	B	B	B

MATERIALS TECHNICAL DATA

CANOPY	FABRIC CODE	SUPPLIER
UPPER SURFACE	30 DMF / N20 DMF	DOMINICO TEX CO (KOREA)
BOTTOM SURFACE	2044 32 PS	DOMINICO TEX CO (KOREA)
PROFILES	30 DFM / 2044 32 FM	DOMINICO TEX CO (KOREA)
DIAGONALS	30 DFM / 2044 32 FM	DOMINICO TEX CO (KOREA)
LOOPS	LKI - 10	KOLON IND. (KOREA)
REINFORCEMENT LOOPS	RIPSTOP FABRIC	DOMINICO TEX CO (KOREA)
TRAILING EDGE REINFORCEMENT	MYLAR	D-P (GERMANY)
RIBS REINFORCEMENT	LTN-0.8 STICK	SPORTWARE CO.CHINA
THREAD	SERAFIL 60	AMAN (GERMANY)

SUSPENSION LINES	FABRIC CODE	SUPPLIER
UPPER CASCADES	DC - 60	LIROS GMHB (GERMANY)
UPPER CASCADES	DC - 40	LIROS GMHB (GERMANY)
MIDDLE CASCADES	DC - 60	LIROS GMHB (GERMANY)
MIDDLE CASCADES	DC - 40	LIROS GMHB (GERMANY)
MIDDLE CASCADES	A-8000/U 70	EDELRID (GERMANY)
MIDDLE CASCADES	A-8000/U 90	EDELRID (GERMANY)
MIDDLE CASCADES	A-8000/U 130	EDELRID (GERMANY)
MAIN	A-8000/U 90	EDELRID (GERMANY)
MAIN	A-8000/U 130	EDELRID (GERMANY)
MAIN	A-8000/U 190	EDELRID (GERMANY)
MAIN	A-8000/U 230	EDELRID (GERMANY)
MAIN BREAK	TNL - 280	TEIJIM LIMITED (JAPAN)
THREAD	SERAFIL 60	AMAN (GERMANY)

RISERS	FABRIC CODE	SUPPLIER
MATERIAL	3455	COUSIN (FRANCE)
COLOR INDICATOR	210D	TECNI SANGLES (FRANCE)
THREAD	V138	COATS (ENGLAND)
MAILLONS	3.5	ANSUNG PRECISION (KOREA)
PULLEYS	RF25109	RONSTAN (AUSTRALIA)

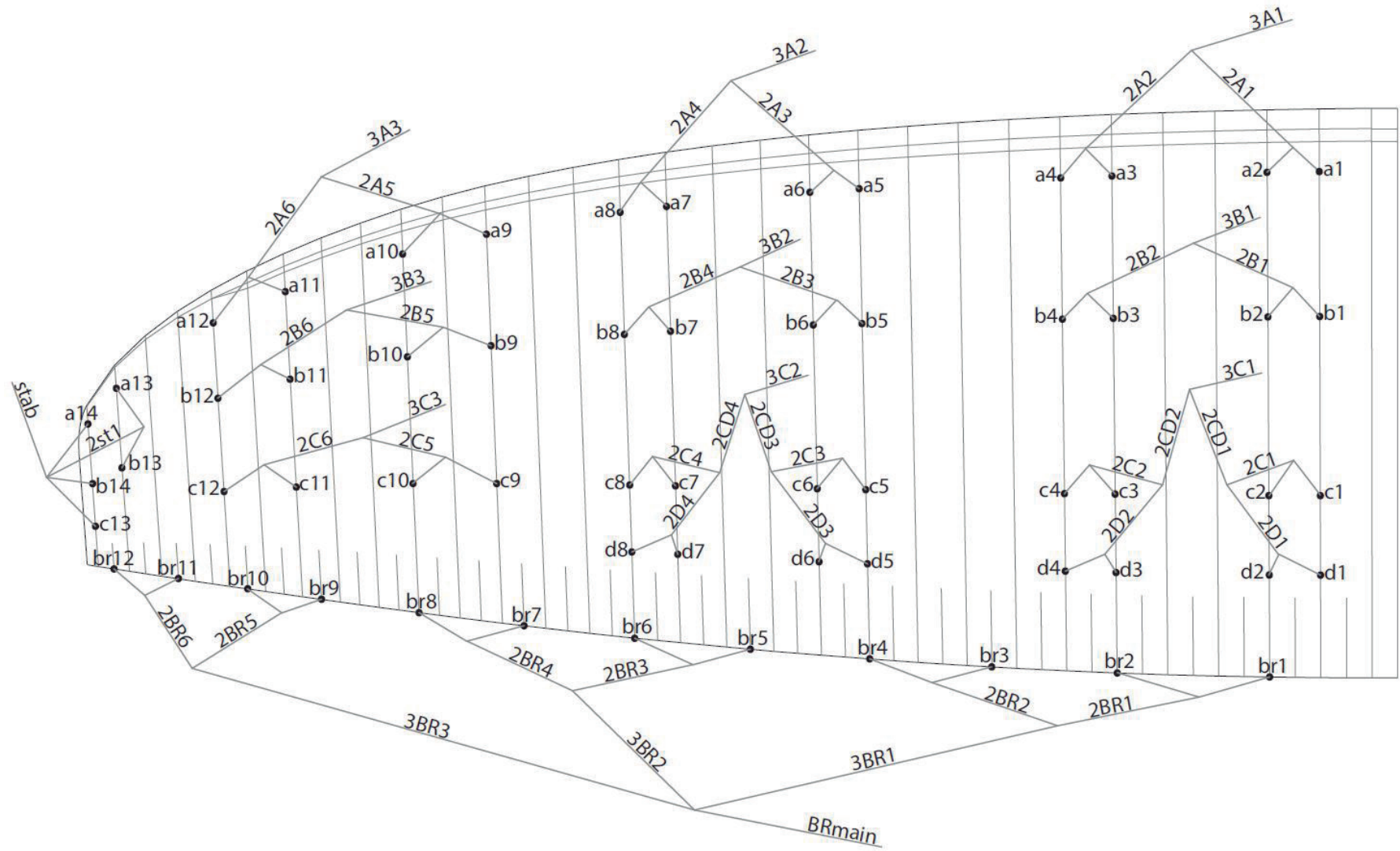

A	A'	B	C
3A1	3A3	3B1	3C1
3A2		3B2	3C2
		3B3	3C3
		stab	

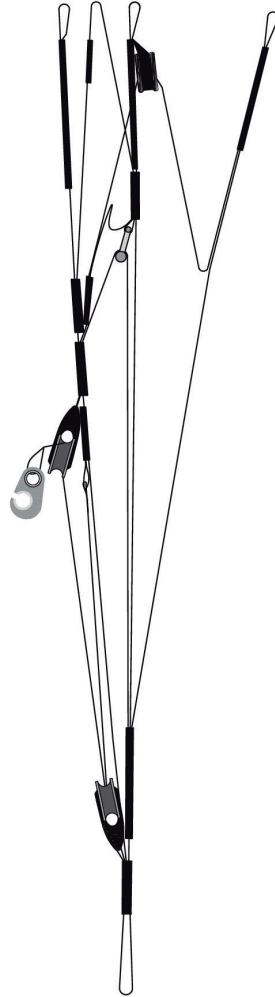

COLORS TECHNICAL DATA

GALA	SB1	DRAGON RED	TOP	REF: 636
	SB2	WHITE	BOTTOM - ALL WHITE	REF: 001
	SB3	SPECTRA GREEN	HORN	REF: 17-5335
	SB4	BLACK	SHADOW	REF: 102
	SB5	WHITE	VOLUME SHADOW	REF: 001



ATOM	SB1	SLATE BLUE	TOP	REF: 317
	SB2	WHITE	BOTTOM - ALL WHITE	REF: 001
	SB3	WHITE	HORN	REF: 001
	SB4	BLACK	SHADOW	REF: 102
	SB5	GOLD	VOLUME SHADOW	REF: 939



OASIS	SB1	GOLD	TOP	REF: 939
	SB2	WHITE	BOTTOM - ALL WHITE	REF: 001
	SB3	SLATE BLUE	HORN	REF: 317
	SB4	WHITE	SHADOW	REF: 001
	SB5	BLACK	VOLUME SHADOW	REF: 102



JAVA	SB1	SPECTRA GREEN	TOP	REF: 17-5335
	SB2	WHITE	BOTTOM - ALL WHITE	REF: 001
	SB3	ORANGE	HORN	REF: 744
	SB4	BLACK	SHADOW	REF: 102
	SB5	WHITE	VOLUME SHADOW	REF: 001



WING LOAD TECHNICAL DATA

IKUMA 2

22		24		26		28		30	
P.T.V.	KG/M2	P.T.V.	KG/M2	P.T.V.	KG/M2	P.T.V.	KG/M2	P.T.V.	KG/M2
65	= 2,95	75	= 3,13	85	= 3,27	95	= 3,39	105	= 3,50
66	= 3,00	76	= 3,17	86	= 3,31	96	= 3,43	106	= 3,53
67	= 3,05	77	= 3,21	87	= 3,35	97	= 3,46	107	= 3,57
68	= 3,09	78	= 3,25	88	= 3,38	98	= 3,50	108	= 3,60
69	= 3,14	79	= 3,29	89	= 3,42	99	= 3,54	109	= 3,63
70	= 3,18	80	= 3,33	90	= 3,46	100	= 3,57	110	= 3,67
71	= 3,23	81	= 3,38	91	= 3,50	101	= 3,61	111	= 3,70
72	= 3,27	82	= 3,42	92	= 3,54	102	= 3,64	112	= 3,73
73	= 3,32	83	= 3,46	93	= 3,58	103	= 3,68	113	= 3,77
74	= 3,36	84	= 3,50	94	= 3,62	104	= 3,71	114	= 3,80
75	= 3,41	85	= 3,54	95	= 3,65	105	= 3,75	115	= 3,83
76	= 3,45	86	= 3,58	96	= 3,69	106	= 3,79	116	= 3,87
77	= 3,50	87	= 3,63	97	= 3,73	107	= 3,82	117	= 3,90
78	= 3,55	88	= 3,67	98	= 3,77	108	= 3,86	118	= 3,93
79	= 3,59	89	= 3,71	99	= 3,81	109	= 3,89	119	= 3,97
80	= 3,64	90	= 3,75	100	= 3,85	110	= 3,93	120	= 4,00
81	= 3,68	91	= 3,79	101	= 3,88	111	= 3,96	121	= 4,03
82	= 3,73	92	= 3,83	102	= 3,92	112	= 4,00	122	= 4,07
83	= 3,77	93	= 3,88	103	= 3,96	113	= 4,04	123	= 4,10
84	= 3,82	94	= 3,92	104	= 4,00	114	= 4,07	124	= 4,13
85	= 3,86	95	= 3,96	105	= 4,04	115	= 4,11	125	= 4,17
								126	= 4,20
								127	= 4,23
								128	= 4,27
								129	= 4,30
								130	= 4,33

LINES TECHNICAL DATA

IKUMA 2

22

REF.	MAT.	kg	COLOUR	mm	REF.	MAT.	kg	COLOUR	mm	REF.	MAT.	kg	COLOUR	mm	REF.	MAT.	kg	COLOUR	mm	ref.	mat.	kg	COLOUR	mm
a1	DC	60	WHT	300	b1	DC	60	WHT	297	c1	DC	40	WHT	300	d1	DC	40	WHT	301	br1	DC	40	WHT	844
a2	DC	60	WHT	252	b2	DC	60	WHT	249	c2	DC	40	WHT	236	d2	DC	40	WHT	241	br2	DC	40	WHT	426
a3	DC	60	WHT	273	b3	DC	60	WHT	269	c3	DC	40	WHT	259	d3	DC	40	WHT	264	br3	DC	40	WHT	601
a4	DC	60	WHT	283	b4	DC	60	WHT	279	c4	DC	40	WHT	287	d4	DC	40	WHT	286	br4	DC	40	WHT	628
a5	DC	60	WHT	279	b5	DC	60	WHT	274	c5	DC	40	WHT	279	d5	DC	40	WHT	281	br5	DC	40	WHT	635
a6	DC	60	WHT	246	b6	DC	40	WHT	242	c6	DC	40	WHT	232	d6	DC	40	WHT	234	br6	DC	40	WHT	474
a7	DC	60	WHT	245	b7	DC	40	WHT	239	c7	DC	40	WHT	231	d7	DC	40	WHT	245	br7	DC	40	WHT	458
a8	DC	60	WHT	259	b8	DC	60	WHT	255	c8	DC	40	WHT	260	d8	DC	40	WHT	255	br8	DC	40	WHT	573
a9	DC	60	WHT	551	b9	DC	40	WHT	535	c9	DC	40	WHT	535						br9	DC	40	WHT	395
a10	DC	40	WHT	468	b10	DC	40	WHT	458	c10	DC	40	WHT	452						br10	DC	40	WHT	341
a11	DC	40	WHT	520	b11	DC	40	WHT	492	c11	DC	40	WHT	481						br11	DC	40	WHT	298
a12	DC	40	WHT	492	b12	DC	40	WHT	456	c12	DC	40	WHT	450						br12	DC	40	WHT	380
a13	DC	40	WHT	764	b13	DC	40	WHT	741	c13	DC	40	WHT	1498										
a14	DC	40	WHT	1438	b14	DC	40	WHT	1436															
2A1	8000/U	130	NATURAL	1833	2B1	8000/U	130	NATURAL	1809	2C1	8000/U	70	NATURAL	510	2D1	8000/U	70	NATURAL	592	2BR1	DC	40	WHT	1.000
2A2	8000/U	130	NATURAL	1773	2B2	8000/U	130	NATURAL	1750	2C2	8000/U	70	NATURAL	475	2D2	8000/U	70	Natural	555	2BR2	DC	40	WHT	681
2A3	8000/U	130	Natural	1691	2B3	8000/U	130	Natural	1658	2C3	8000/U	70	NATURAL	470	2D3	8000/U	70	Natural	546	2BR3	DC	40	WHT	806
2A4	8000/U	90	NATURAL	1639	2B4	8000/U	90	NATURAL	1615	2C4	8000/U	70	NATURAL	454	2D4	8000/U	70	NATURAL	512	2BR4	DC	40	WHT	787
2A5	8000/U	70	NATURAL	1541	2B5	8000/U	70	NATURAL	1515	2C5	8000/U	70	NATURAL	1354						2BR5	DC	40	WHT	491
2A6	8000/U	70	NATURAL	1392	2B6	8000/U	70	NATURAL	1398	2C6	8000/U	70	NATURAL	1243						2BR6	DC	40	WHT	509
					2ST1	DC	40	WHT	741	2CD1	8000/U	90	NATURAL	778						3BR1	DC	60	WHT	2501
					STAB	8000/U	90	NATURAL	4202	2CD2	8000/U	90	NATURAL	750						3BR2	DC	60	WHT	2219
										2CD3	8000/U	70	NATURAL	729						3BR3	DC	60	WHT	2542
										2CD4	8000/U	70	NATURAL	700										
3A1	8000/U	230	NATURAL	4313	3B1	8000/U	190	NATURAL	4247	3C1	8000/U	190	NATURAL	4870						BRMAIN	TNL	280	RED	3205
3A2	8000/U	190	NATURAL	4339	3B2	8000/U	130	NATURAL	4288	3C2	8000/U	130	NATURAL	4847										KNOT POINT: 3005
3A3	8000/U	130	NATURAL	4063	3B3	8000/U	90	NATURAL	4038	3C3	8000/U	90	NATURAL	4273										

LINES TECHNICAL DATA

IKUMA 2

24

REF.	MAT.	kg	COLOUR	mm	REF.	MAT.	kg	COLOUR	mm	REF.	MAT.	kg	COLOUR	mm	REF.	MAT.	kg	COLOUR	mm	ref.	mat.	kg	COLOUR	mm
a1	DC	60	WHT	314	b1	DC	60	WHT	310	c1	DC	40	WHT	313	d1	DC	40	WHT	314	br1	DC	40	WHT	891
a2	DC	60	WHT	264	b2	DC	60	WHT	260	c2	DC	40	WHT	247	d2	DC	40	WHT	253	br2	DC	40	WHT	463
a3	DC	60	WHT	285	b3	DC	60	WHT	281	c3	DC	40	WHT	270	d3	DC	40	WHT	276	br3	DC	40	WHT	638
a4	DC	60	WHT	296	b4	DC	60	WHT	292	c4	DC	40	WHT	300	d4	DC	40	WHT	299	br4	DC	40	WHT	654
a5	DC	60	WHT	291	b5	DC	60	WHT	286	c5	DC	40	WHT	291	d5	DC	40	WHT	293	br5	DC	40	WHT	666
a6	DC	60	WHT	257	b6	DC	40	WHT	253	c6	DC	40	WHT	243	d6	DC	40	WHT	245	br6	DC	40	WHT	491
a7	DC	60	WHT	255	b7	DC	40	WHT	249	c7	DC	40	WHT	241	d7	DC	40	WHT	255	br7	DC	40	WHT	475
a8	DC	60	WHT	270	b8	DC	60	WHT	266	c8	DC	40	WHT	272	d8	DC	40	WHT	267	br8	DC	40	WHT	598
a9	DC	60	WHT	575	b9	DC	40	WHT	559	C9	DC	40	WHT	559						br9	DC	40	WHT	408
a10	DC	40	WHT	489	b10	DC	40	WHT	478	C10	DC	40	WHT	472						br10	DC	40	WHT	358
a11	DC	40	WHT	543	b11	DC	40	WHT	514	C11	DC	40	WHT	502						BR11	DC	40	WHT	319
a12	DC	40	WHT	514	B12	DC	40	WHT	477	C12	DC	40	WHT	470						BR12	DC	40	WHT	401
a13	DC	40	WHT	798	B13	DC	40	WHT	774	C13	DC	40	WHT	1565										
a14	DC	40	WHT	1502	B14	DC	40	WHT	1500															
2A1	8000/U	130	NATURAL	1914	2B1	8000/U	130	NATURAL	1.889	2C1	8000/U	70	NATURAL	533	2D1	8000/U	70	NATURAL	618	2BR1	DC	40	WHT	1.067
2A2	8000/U	130	NATURAL	1853	2B2	8000/U	130	NATURAL	1.829	2C2	8000/U	70	NATURAL	497	2D2	8000/U	70	Natural	581	2BR2	DC	40	WHT	727
2A3	8000/U	130	Natural	1765	2B3	8000/U	130	Natural	1.732	2C3	8000/U	70	NATURAL	491	2D3	8000/U	70	Natural	570	2BR3	DC	40	WHT	844
2A4	8000/U	90	NATURAL	1712	2B4	8000/U	90	NATURAL	1.687	2C4	8000/U	70	NATURAL	475	2D4	8000/U	70	NATURAL	535	2BR4	DC	40	WHT	818
2A5	8000/U	70	NATURAL	1609	2B5	8000/U	70	NATURAL	1.582	2C5	8000/U	70	NATURAL	1414						2BR5	DC	40	WHT	513
2A6	8000/U	70	NATURAL	1454	2B6	8000/U	70	NATURAL	1461	2C6	8000/U	70	NATURAL	1298						2BR6	DC	40	WHT	529
					2ST1	DC	40	WHT	774	2CD1	8000/U	90	NATURAL	812						3BR1	DC	60	WHT	2606
					STAB	8000/U	90	NATURAL	4417	2CD2	8000/U	90	NATURAL	784						3BR2	DC	60	WHT	2313
										2CD3	8000/U	70	NATURAL	761						3BR3	DC	60	WHT	2661
										2CD4	8000/U	70	NATURAL	731										
3A1	8000/U	230	NATURAL	4527	3B1	8000/U	190	NATURAL	4458	3C1	8000/U	190	NATURAL	5109						BRMAIN	TNL	280	RED	3339
3A2	8000/U	190	NATURAL	4558	3B2	8000/U	130	NATURAL	4504	3C2	8000/U	130	NATURAL	5088										KNOT POINT: 3139
3A3	8000/U	130	NATURAL	4271	3B3	8000/U	90	NATURAL	4245	3C3	8000/U	90	NATURAL	4490										

LINES TECHNICAL DATA

IKUMA 2

26

REF.	MAT.	KG	COLOUR	MM	REF.	MAT.	KG	COLOUR	MM	REF.	MAT.	KG	COLOUR	MM	REF.	MAT.	KG	COLOUR	MM	REF.	MAT.	KG	COLOUR	MM
a1	DC	60	WHT	326	b1	DC	60	WHT	322	c1	DC	40	WHT	326	d1	DC	40	WHT	327	br1	DC	40	WHT	918
a2	DC	60	WHT	275	b2	DC	60	WHT	271	c2	DC	40	WHT	257	d2	DC	40	WHT	263	br2	DC	40	WHT	464
a3	DC	60	WHT	296	b3	DC	60	WHT	292	c3	DC	40	WHT	280	d3	DC	40	WHT	287	br3	DC	40	WHT	652
a4	DC	60	WHT	308	b4	DC	60	WHT	304	c4	DC	40	WHT	312	d4	DC	40	WHT	311	br4	DC	40	WHT	684
a5	DC	60	WHT	303	b5	DC	60	WHT	297	c5	DC	40	WHT	303	d5	DC	40	WHT	305	br5	DC	40	WHT	690
a6	DC	60	WHT	268	b6	DC	40	WHT	264	c6	DC	40	WHT	253	d6	DC	40	WHT	255	br6	DC	40	WHT	517
a7	DC	60	WHT	266	b7	DC	40	WHT	259	c7	DC	40	WHT	250	d7	DC	40	WHT	266	br7	DC	40	WHT	496
a8	DC	60	WHT	281	b8	DC	60	WHT	277	c8	DC	40	WHT	283	d8	DC	40	WHT	278	br8	DC	40	WHT	623
a9	DC	60	WHT	599	b9	DC	40	WHT	581	c9	DC	40	WHT	582						br9	DC	40	WHT	429
A10	DC	40	WHT	509	b10	DC	40	WHT	498	c10	DC	40	WHT	491						br10	DC	40	WHT	371
A11	DC	40	WHT	566	b11	DC	40	WHT	535	c11	DC	40	WHT	523						br11	DC	40	WHT	323
A12	DC	40	WHT	535	b12	DC	40	WHT	496	c12	DC	40	WHT	490						br12	DC	40	WHT	414
A13	DC	40	WHT	831	b13	DC	40	WHT	805	c13	DC	40	WHT	1629										
A14	DC	40	WHT	1564	b14	DC	40	WHT	1561															
2A1	8000/U	130	NATURAL	1991	2B1	8000/U	130	NATURAL	1.965	2C1	8000/U	70	NATURAL	554	2D1	8000/U	70	NATURAL	643	2BR1	DC	40	WHT	1.084
2A2	8000/U	130	NATURAL	1930	2B2	8000/U	130	NATURAL	1.906	2C2	8000/U	70	NATURAL	518	2D2	8000/U	70	NATURAL	605	2BR2	DC	40	WHT	742
2A3	8000/U	130	NATURAL	1837	2B3	8000/U	130	NATURAL	1.802	2C3	8000/U	70	NATURAL	511	2D3	8000/U	70	NATURAL	593	2BR3	DC	40	WHT	874
2A4	8000/U	90	NATURAL	1783	2B4	8000/U	90	NATURAL	1.757	2C4	8000/U	70	NATURAL	494	2D4	8000/U	70	NATURAL	558	2BR4	DC	40	WHT	859
2A5	8000/U	70	NATURAL	1675	2B5	8000/U	70	NATURAL	1.647	2C5	8000/U	70	NATURAL	1472						2BR5	DC	40	WHT	533
2A6	8000/U	70	NATURAL	1514	2B6	8000/U	70	NATURAL	1521	2C6	8000/U	70	NATURAL	1351						2BR6	DC	40	WHT	555
					2ST1	DC	40	WHT	806	2CD1	8000/U	90	NATURAL	845						3BR1	DC	60	WHT	2713
					STAB	8000/U	90	NATURAL	4623	2CD2	8000/U	90	NATURAL	816						3BR2	DC	60	WHT	2414
										2CD3	8000/U	70	NATURAL	792						3BR3	DC	60	WHT	2771
										2CD4	8000/U	70	NATURAL	761										
3A1	8000/U	230	NATURAL	4733	3B1	8000/U	190	NATURAL	4660	3C1	8000/U	190	NATURAL	5338						BRMAIN	TNL	280	RED	3485
3A2	8000/U	190	NATURAL	4768	3B2	8000/U	130	NATURAL	4713	3C2	8000/U	130	NATURAL	5319										KNOT POINT: 3285
3A3	8000/U	130	NATURAL	4471	3B3	8000/U	90	NATURAL	4445	3C3	8000/U	90	NATURAL	4698										

LINES TECHNICAL DATA

IKUMA 2

28

REF.	MAT.	kg	COLOUR	mm	REF.	MAT.	kg	COLOUR	mm	REF.	MAT.	kg	COLOUR	mm	REF.	MAT.	kg	COLOUR	mm	ref.	mat.	kg	COLOUR	mm
a1	DC	60	WHT	338	b1	DC	60	WHT	334	c1	DC	40	WHT	338	d1	DC	40	WHT	339	br1	DC	40	WHT	953
a2	DC	60	WHT	286	b2	DC	60	WHT	282	c2	DC	40	WHT	267	d2	DC	40	WHT	274	br2	DC	40	WHT	482
a3	DC	60	WHT	307	b3	DC	60	WHT	303	c3	DC	40	WHT	291	d3	DC	40	WHT	297	br3	DC	40	WHT	676
a4	DC	60	WHT	320	b4	DC	60	WHT	316	c4	DC	40	WHT	324	d4	DC	40	WHT	323	br4	DC	40	WHT	710
a5	DC	60	WHT	314	b5	DC	60	WHT	308	c5	DC	40	WHT	314	d5	DC	40	WHT	316	br5	DC	40	WHT	716
a6	DC	60	WHT	278	b6	DC	40	WHT	274	c6	DC	40	WHT	263	d6	DC	40	WHT	265	br6	DC	40	WHT	537
a7	DC	60	WHT	276	b7	DC	40	WHT	269	c7	DC	40	WHT	260	d7	DC	40	WHT	276	br7	DC	40	WHT	514
a8	DC	60	WHT	292	b8	DC	60	WHT	288	c8	DC	40	WHT	294	D8	DC	40	WHT	288	br8	DC	40	WHT	647
a9	DC	60	WHT	621	b9	DC	40	WHT	603	c9	DC	40	WHT	604						br9	DC	40	WHT	445
a10	DC	40	WHT	528	B10	DC	40	WHT	517	c10	DC	40	WHT	510						BR10	DC	40	WHT	386
a11	DC	40	WHT	587	B11	DC	40	WHT	555	c11	DC	40	WHT	542						BR11	DC	40	WHT	335
a12	DC	40	WHT	556	B12	DC	40	WHT	515	c12	DC	40	WHT	508						BR12	DC	40	WHT	429
a13	DC	40	WHT	862	B13	DC	40	WHT	836	c13	DC	40	WHT	1690										
a14	DC	40	WHT	1623	B14	DC	40	WHT	1620															
2A1	8000/U	130	NATURAL	2065	2B1	8000/U	130	NATURAL	2.038	2C1	8000/U	70	NATURAL	574	2D1	8000/U	70	NATURAL	666	2BR1	DC	40	WHT	1.124
2A2	8000/U	130	NATURAL	2005	2B2	8000/U	130	NATURAL	1.979	2C2	8000/U	70	NATURAL	538	2D2	8000/U	70	NATURAL	628	2BR2	DC	40	WHT	771
2A3	8000/U	130	NATURAL	1906	2B3	8000/U	130	NATURAL	1.869	2C3	8000/U	70	NATURAL	530	2D3	8000/U	70	NATURAL	615	2BR3	DC	40	WHT	906
2A4	8000/U	90	NATURAL	1851	2B4	8000/U	90	NATURAL	1.824	2C4	8000/U	70	NATURAL	513	2D4	8000/U	70	NATURAL	579	2BR4	DC	40	WHT	892
2A5	8000/U	70	NATURAL	1738	2B5	8000/U	70	NATURAL	1.709	2C5	8000/U	70	NATURAL	1527						2BR5	DC	40	WHT	553
2A6	8000/U	70	NATURAL	1571	2B6	8000/U	70	NATURAL	1578	2C6	8000/U	70	NATURAL	1402						2BR6	DC	40	WHT	577
					2ST1	DC	40	WHT	837	2CD1	8000/U	90	NATURAL	876						3BR1	DC	60	WHT	2812
					STAB	8000/U	90	NATURAL	4822	2CD2	8000/U	90	NATURAL	848						3BR2	DC	60	WHT	2506
										2CD3	8000/U	70	NATURAL	822						3BR3	DC	60	WHT	2879
										2CD4	8000/U	70	NATURAL	790										
3A1	8000/U	230	NATURAL	4931	3B1	8000/U	190	NATURAL	4855	3C1	8000/U	190	NATURAL	5558						BRMAIN	TNL	280	RED	3597
3A2	8000/U	190	NATURAL	4971	3B2	8000/U	130	NATURAL	4913	3C2	8000/U	130	NATURAL	5542										KNOT POINT: 3397
3A3	8000/U	130	NATURAL	4664	3B3	8000/U	90	NATURAL	4636	3C3	8000/U	90	NATURAL	4899										

LINES TECHNICAL DATA

IKUMA 2

30

REF.	MAT.	KG	COLOUR	MM	REF.	MAT.	KG	COLOUR	MM	REF.	MAT.	KG	COLOUR	MM	REF.	MAT.	KG	COLOUR	MM	REF.	MAT.	KG	COLOUR	MM
a1	DC	60	WHT	350	b1	DC	60	WHT	346	c1	DC	40	WHT	350	d1	DC	40	WHT	351	br1	DC	40	WHT	986
a2	DC	60	WHT	296	b2	DC	60	WHT	292	c2	DC	40	WHT	277	d2	DC	40	WHT	283	br2	DC	40	WHT	500
a3	DC	60	WHT	317	b3	DC	60	WHT	313	c3	DC	40	WHT	301	d3	DC	40	WHT	308	br3	DC	40	WHT	700
a4	DC	60	WHT	331	b4	DC	60	WHT	327	c4	DC	40	WHT	336	d4	DC	40	WHT	335	br4	DC	40	WHT	735
a5	DC	60	WHT	325	b5	DC	60	WHT	319	c5	DC	40	WHT	325	d5	DC	40	WHT	328	br5	DC	40	WHT	741
a6	DC	60	WHT	288	b6	DC	40	WHT	284	c6	DC	40	WHT	272	d6	DC	40	WHT	274	br6	DC	40	WHT	557
a7	DC	60	WHT	285	b7	DC	40	WHT	278	c7	DC	40	WHT	269	d7	DC	40	WHT	285	br7	DC	40	WHT	532
a8	DC	60	WHT	303	b8	DC	60	WHT	298	c8	DC	40	WHT	304	d8	DC	40	WHT	298	br8	DC	40	WHT	670
a9	DC	60	WHT	643	b9	DC	40	WHT	625	c9	DC	40	WHT	625						br9	DC	40	WHT	461
a10	DC	40	WHT	547	b10	DC	40	WHT	535	c10	DC	40	WHT	528						br10	DC	40	WHT	399
a11	DC	40	WHT	607	b11	DC	40	WHT	574	c11	DC	40	WHT	561						br11	DC	40	WHT	346
a12	DC	40	WHT	575	b12	DC	40	WHT	533	c12	DC	40	WHT	526						br12	DC	40	WHT	444
a13	DC	40	WHT	892	b13	DC	40	WHT	865	c13	DC	40	WHT	1749										
a14	DC	40	WHT	1680	b14	DC	40	WHT	1677															
2A1	8000/U	130	NATURAL	2137	2B1	8000/U	130	NATURAL	2.109	2C1	8000/U	70	NATURAL	594	2D1	8000/U	70	NATURAL	689	2BR1	DC	40	WHT	1.163
2A2	8000/U	130	NATURAL	2076	2B2	8000/U	130	NATURAL	2.049	2C2	8000/U	70	NATURAL	558	2D2	8000/U	70	NATURAL	651	2BR2	DC	40	WHT	799
2A3	8000/U	130	NATURAL	1973	2B3	8000/U	130	NATURAL	1.935	2C3	8000/U	70	NATURAL	548	2D3	8000/U	70	NATURAL	637	2BR3	DC	40	WHT	936
2A4	8000/U	90	NATURAL	1917	2B4	8000/U	90	NATURAL	1.889	2C4	8000/U	70	NATURAL	532	2D4	8000/U	70	NATURAL	600	2BR4	DC	40	WHT	925
2A5	8000/U	70	NATURAL	1799	2B5	8000/U	70	NATURAL	1.769	2C5	8000/U	70	NATURAL	1581						2BR5	DC	40	WHT	572
2A6	8000/U	70	NATURAL	1626	2B6	8000/U	70	NATURAL	1634	2C6	8000/U	70	NATURAL	1452						2BR6	DC	40	WHT	598
					2ST1	DC	40	WHT	866	2CD1	8000/U	90	NATURAL	907						3BR1	DC	60	WHT	2909
					STAB	8000/U	90	NATURAL	5013	2CD2	8000/U	90	NATURAL	878						3BR2	DC	60	WHT	2594
										2CD3	8000/U	70	NATURAL	850						3BR3	DC	60	WHT	2984
										2CD4	8000/U	70	NATURAL	818										
3A1	8000/U	230	NATURAL	5121	3B1	8000/U	190	NATURAL	5043	3C1	8000/U	190	NATURAL	5771						BRMAIN	TNL	280	RED	3734
3A2	8000/U	190	NATURAL	5166	3B2	8000/U	130	NATURAL	5106	3C2	8000/U	130	NATURAL	5757										KNOT POINT: 3534
3A3	8000/U	130	NATURAL	4849	3B3	8000/U	90	NATURAL	4821	3C3	8000/U	90	NATURAL	5092										

NIVIUK IKUMA 2 22

LINES HEIGHT + RISER mm

	A	B	C	D	BR
1	6930	6841	6938	7021	7384
2	6882	6794	6874	6961	6965
3	6842	6754	6833	6919	6822
4	6852	6765	6862	6941	6850
5	6794	6710	6807	6885	6699
6	6761	6678	6761	6839	6538
7	6710	6633	6714	6786	6503
8	6724	6648	6744	6797	6618
9	6645	6577	6652		6468
10	6562	6499	6568		6413
11	6468	6417	6486		6388
12	6440	6381	6456		6470
13	6195	6172	6190		
14	6128	6126			

RISER LENGHT mm

	A	B	C	
	470	470	470	STANDARD
	325	390	490	ACCELERATED

NIVIUK IKUMA 2 24

LINES HEIGHT + RISER mm

	A	B	C	D	BR
1	7242	7144	7245	7330	7723
2	7192	7094	7179	7270	7300
3	7152	7055	7140	7230	7135
4	7163	7066	7170	7253	7151
5	7101	7009	7111	7192	6987
6	7067	6976	7063	7144	6812
7	7012	6927	7015	7089	6770
8	7027	6944	7046	7101	6893
9	6945	6873	6943		6746
10	6859	6792	6856		6696
11	6758	6707	6770		6673
12	6729	6670	6738		6755
13	6476	6452	6469		
14	6406	6404			

RISER LENGHT mm

	A	B	C	
	470	470	470	STANDARD
	325	390	490	ACCELERATED

NIVIUK IKUMA 2 26

LINES HEIGHT + RISER mm

	A	B	C	D	BR
1	7540	7435	7525	7615	8053
2	7487	7385	7462	7551	7588
3	7448	7345	7413	7503	7437
4	7460	7358	7446	7531	7468
5	7396	7296	7399	7474	7305
6	7364	7263	7350	7429	7134
7	7309	7212	7297	7379	7098
8	7319	7227	7326	7393	7219
9	7236	7153	7236		7064
10	7149	7075	7142		7004
11	7048	6986	7050		6974
12	7015	6947	7014		7067
13	6751	6727	6739		
14	6682	6677			

RISER LENGHT mm

	A	B	C	
	470	470	470	STANDARD
	325	390	490	ACCELERATED

NIVIUK IKUMA 2 28

LINES HEIGHT + RISER mm

	A	B	C	D	BR
1	7820	7716	7828	7921	8321
2	7768	7664	7756	7855	7851
3	7728	7625	7715	7812	7692
4	7741	7638	7749	7838	7726
5	7680	7579	7689	7777	7560
6	7644	7544	7637	7725	7381
7	7586	7494	7587	7668	7344
8	7603	7513	7621	7681	7477
9	7512	7438	7515		7310
10	7418	7351	7421		7250
11	7310	7259	7328		7223
12	7279	7219	7294		7317
13	7008	6982	7005		
14	6935	6933			

RISER LENGHT mm

	A	B	C	
	470	470	470	STANDARD
	325	390	490	ACCELERATED

LINES HEIGHT + RISER mm

	A	B	C	D	BR
1	8094	7986	8101	8198	8627
2	8041	7933	8028	8130	8140
3	8001	7894	7987	8087	7977
4	8015	7908	8022	8114	8012
5	7950	7850	7963	8055	7841
6	7912	7815	7911	8001	7657
7	7856	7765	7859	7943	7620
8	7873	7784	7895	7956	7758
9	7782	7704	7788		7585
10	7686	7614	7691		7524
11	7576	7519	7595		7496
12	7544	7478	7560		7594
13	7267	7240	7258		
14	7189	7186			

RISER LENGHT mm

	A	B	C	
	470	470	470	STANDARD
	325	390	490	ACCELERATED

SUSPENSION TECHNICAL DATA

IKUMA 2

MATERIAL CODE		DC	DC	A-8000/U	8000/U	A-8000/U	A-8000/U	A-8000/U	TNL
STRENGTH CODE		040	060	070	90	130	190	230	280
DIAMETER mm	Ø	0,5	0,6	0,7	0,8	0,9	1,1	1,1 X 1,4	1,8
CORE MATERIAL		DYNEEMA	DYNEEMA	ARAMID	ARAMID	ARAMID	ARAMID	ARAMID	TECHNORA
SLEEVE MATERIAL		NO	NO	NO	NO	NO	NO	NO	POLYESTER
WEIGHT G/M	TOTAL	0,19	0,24	0,4	0,5	0,8	1,1	1,4	2,7
BREAKING STRENGTH	MINIMUM	40	60	70	90	130	190	230	280
	MAXIMUM	48	84	78	110	144	211	255	320
STRENGTH AFTER									
5.000 BENDING	TEST EN	33	74	39	49	88	52	69	134,7
CYCLES									
ELONGATION AT	5 DAN EN %			0,5	0,4	0,4	0,4	0,3	0,2
	10 DAN EN %		0,43	0,7	0,6	0,6	0,6	0,5	0,3
	15 DAN EN %			1	0,8	0,8	0,7	0,6	0,4
	20 DAN EN %			1,3	1	0,9	0,9	0,7	0,4
	25 DAN EN %			1,5	1,3	1	1	0,8	0,5
	30 DAN EN %		1,2	2,8	2,3	1,8	1,6	1,3	0,9
	75 DAN EN %			3,7	3,2	3,1	2,7	2,3	1,3
	100 DAN EN %						2,6	3,6	1,7
	125 DAN EN %						3,5	3,3	2
	150 DAN EN %						4,3	3,6	2,3
	175 DAN EN %								2,7
	200 DAN EN %								2,8
ELONGATION MAX. BREAKING STRENGTH %			3,2	3,9	4,3	4	4,4	4,4	4,1

MAILLON TECHNICAL DATA

DESCRIPTION

MAILLON	DELTA
CODE	3.5
MATERIAL	STAINLESS STEEL
SIZE	3 m/m
WEIGHT	5 G/PIECE
QUANTITY	8 PIECES
INSERTS	2 GREEN / 6 BLACK

TECHNICAL SPECIFICATIONS

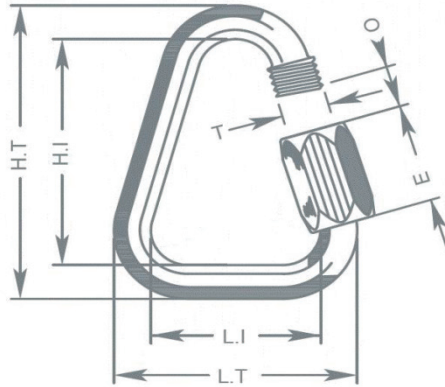

DIMENSIONS	mm
L.T.	22
L.I.	14
H.T.	37
H.I.	29
O	5
E	12
T	4
LOAD	KG
WORKING LIMIT	110
BREAKING	550

MATERIAL

AISI 304 STAINLESS STEEL

STANDARD

CLOSING APPLIED BY MANUAL & ENTIRE SCREWING OF THE NUT

TO GUARANTEE THE HIGHEST SAFETY (NO THREAD SHOULD BE OBVIOUS)

SYSTEMATIC CONTROL OF MAILLON QUICK-LINKS BEFORE EVERY FLIGHT

PULLEY TECHNICAL DATA

DESCRIPTION

PULLEY	20 m/m
CODE	RF25109
MATERIALS	STAINLESS STEEL
	NYLON
	CARBON ACETAL
BEARING	DELRIN®
WEIGHT	14 G/PIECE

TECHNICAL SPECIFICATIONS

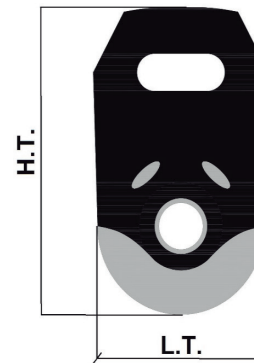

DIMENSIONS	mm
L.T.	20
H.T.	33
Ø	5 MAX
LOAD	KG
WORKING LIMIT	200
BREAKING	400

THREAD TECHNICAL DATA**SAIL MAKING**

NAME	SERAFIL
N° OF REFERENCE	60
MATERIAL	POLYESTER
TYPE OF FINISH	SILK
LINEAR DENSITY	NM 61 / 3 (DTEX 163 * 3)
BREAKING STRENGTH	3,000 CN
ELONGATION	17,00%

SERAFIL PROPERTIES

SOLIDITY ARTIFICIAL LIGTH	ISO 105 B02 > 5 - 6
SOLIDITY SWEAT	ISO 105 E04 > 4
SOLIDITY WASHING	ISO 105 C04 > 3
SOLIDITY GRAZE IN DRY	ISO 105 X12 > 4
SOLIDITY WASHING IN DRY	ISO 105 D01 > 3 - 4

TREATMENT WATER REPELLENT	WR
---------------------------	----

RISERS MAKING

NAME	COATS BONDED C.F.P.
N° OF REFERENCE	V138
MATERIAL	POLYESTER
TYPE OF FINISH	SILK
BREAKING STRENGTH	9,5 KG
ELONGATION	19%

RISERS TECHNICAL DATA**RISERS**

N° OF REFERENCE	3455
MATERIAL	POLYESTER & TECHNORA
WIDTH	12 mm
THICKNESS	2,25 mm
BREAKING STRENGTH	1.100 DAN
ELONGATION	MAX. 11%
WEIGHT	21,1 G/M
COLOR	BLACK

COLOR INDICATOR

N° OF REFERENCE	IC-G 1-2
MATERIAL	POLYESTER
WIDTH	70 Mm
THICKNESS	0,80 Mm
BREAKING STRENGTH	130 DN
ELONGATION	35 %
WEIGHT	32 G * L.M.
COLOR	GREEN

LOOPS

N° OF REFERENCE	LKI - 10
MATERIAL	NYLON
WIDTH	10 Mm
BREAKING STRENGTH	84 KG
ELONGATION	30 %
WEIGHT	5,5 G/M
COLOR	WHITE

